



P.O. Box 787 Iron Mountain, MI 49801-0787  
ISO 9001:2008 REGISTERED  
bossplow.com

**2017 & NEWER FORD SUPER DUTY  
RT3 UNDERCARRIAGE  
MOUNTING INSTRUCTIONS  
(PART NO. LTA10200)**

# WARNING

Many newer trucks are now equipped with air bags. DO NOT under any circumstances disable, remove or relocate any sensors or other components related to the operation of the air bags.

For recommended vehicle models refer to the Boss Snowplow Application Chart and Selection Guide.

To comply with Federal Regulations and to assure a safe vehicle, the Front Gross Axle Weight Rating (FGAWR), Rear Gross Axle Weight Rating (RGAWR), and the Gross Vehicle Weight Rating (GAWR) must not be exceeded at any time.

Due to the variety of equipment that can be installed on this vehicle, it is necessary to verify that the Front Gross Axle Weight Rating (FGAWR), Rear Gross Axle Weight Rating (RGAWR), and the Gross Vehicle Weight Rating (GAWR) are not exceeded at any time. This may require weighing the vehicle and adding ballast as necessary. It may also limit payload capacity of the vehicle. It is the operator's responsibility to verify that these ratings are not exceeded.

## 2017 & NEWER FORD SUPER DUTY RT3 UNDERCARRIAGE MOUNTING INSTRUCTIONS

The mounting procedure outlined below covers 2017 & Newer Ford Super Duty trucks. You will need to refer to the illustrations and familiarize yourself with each of the undercarriage components and their relative position to each other. Ensure that the vehicle is shut off, the key is removed from the ignition, and the parking brake is engaged. Then proceed as follows:

1. Remove the vehicle bumper.
2. Remove front-to-front compatibility brackets.

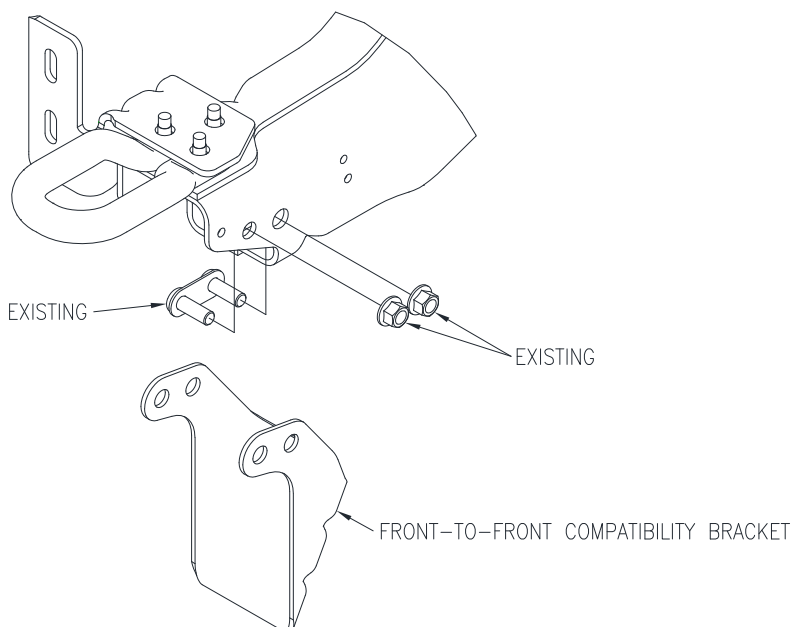

Figure 1

G10617

3. Remove driver side stabilizer bar mounting bracket and remove existing bolts from frame.
  4. Insert Bolt Bars (63) into frame.
  5. Place stabilizer bracket on Bolt Bars (63).
  6. Position Push Beam Support Plate (62B) to align with Bolt Bars (63). Attach using two 3/8" Flat Washers (H), and two 3/8"-16 Nylon Lock Nuts (G). The stabilizer bar bracket must be between the frame and Push Beam Support Plate (62B). Leave fasteners finger tight.
  7. Attach driver side Push Beam Support Plate (62B) using three 5/8"-11 2" GR5 Hex Head bolts (C), three 5/8" Flat Washers (E), three 5/8"-11 Nylon Lock Nuts (F), three 1/2"-13 2" GR5 Hex Head bolts (A), three 1/2" Flat Washers (D), and three 1/2"-13 Nylon Lock Nuts (B). Leave fasteners finger tight.
  8. Repeat for passenger side Push Beam Support Plate (62A).
  9. Bolt Push Beam Assembly (62) onto Push Beam Support Plates (62A & 62B) using 1/2"-13 X 2" GR5 Hex Head Bolts (A) and 1/2"-13 Nylon Lock Nuts (B). Leave fasteners finger tight.
  10. With all the undercarriage parts in place, securely fasten all mounting hardware. It is important that all fasteners be properly torqued (see Figure 3) to assure a safe operating plow. Re-tighten all fasteners after 2 hours of plowing.
- Note:** The proper Push Beam Assembly height is 15-1/2" from the ground to the center of the pin receiving holes on the Push Beam hooks. (See Figure 3)
11. Before replacing the bumper on the truck measure and notch, or remove the lower valance. Relocation of fog light wiring (if equipped) will be required if lower valance is removed.
  12. Replace the bumper on the truck.

**Note:** All original equipment removed from the truck must be remounted if the snowplow undercarriage is removed from the truck.

**Note:** Headlight adapters vary depending on vehicle model year:  
2017 & Newer – Halogen Bulbs (9008/H13) – MSC10230  
2017 & Newer – LED Lamps – MSC09455

## 2017 & NEWER FORD SUPER DUTY RT3 UNDERCARRIAGE MOUNTING INSTRUCTIONS

| REF. NO.  | DESCRIPTION                                       | PART NO. | QTY. |
|-----------|---|----------|------|
| 62        | Push Beam Assembly                                | PBA10201 | 1    |
| 62A       | Push Beam Support Plate Passenger Side            | PBA10203 | 1    |
| 62B       | Push Beam Support Plate Driver Side               | PBA10202 | 1    |
| 63        | Bolt Bar, Ford Super Duty, 17 & Up                | LTA10233 | 4    |
|           | FASTENER KIT, FORD, 2017 & NEWER                  | HDW10215 |      |
| Includes: |   |          |      |
| A         | 1/2"-13 X 2" Hex Head Bolt Grade 5                | HDW01755 | 14   |
| B         | 1/2"-13 Nylon Lock Nut                            | HDW01748 | 14   |
| C         | 5/8"-11 X 2" Hex Head Bolt Grade 5 (2015 & Newer) | HDW01731 | 6    |
| D         | 1/2" Flat Washer                                  | HDW01729 | 6    |
| E         | 5/8" Flat Washer (2015 & Newer)                   | HDW01726 | 6    |
| F         | 5/8"-11 Nylon Lock Nut                            | HDW05619 | 6    |
| G         | 3/8"-16 Nylon Lock Nut                            | HDW01720 | 4    |
| H         | 3/8" Flat Washer                                  | HDW01733 | 4    |

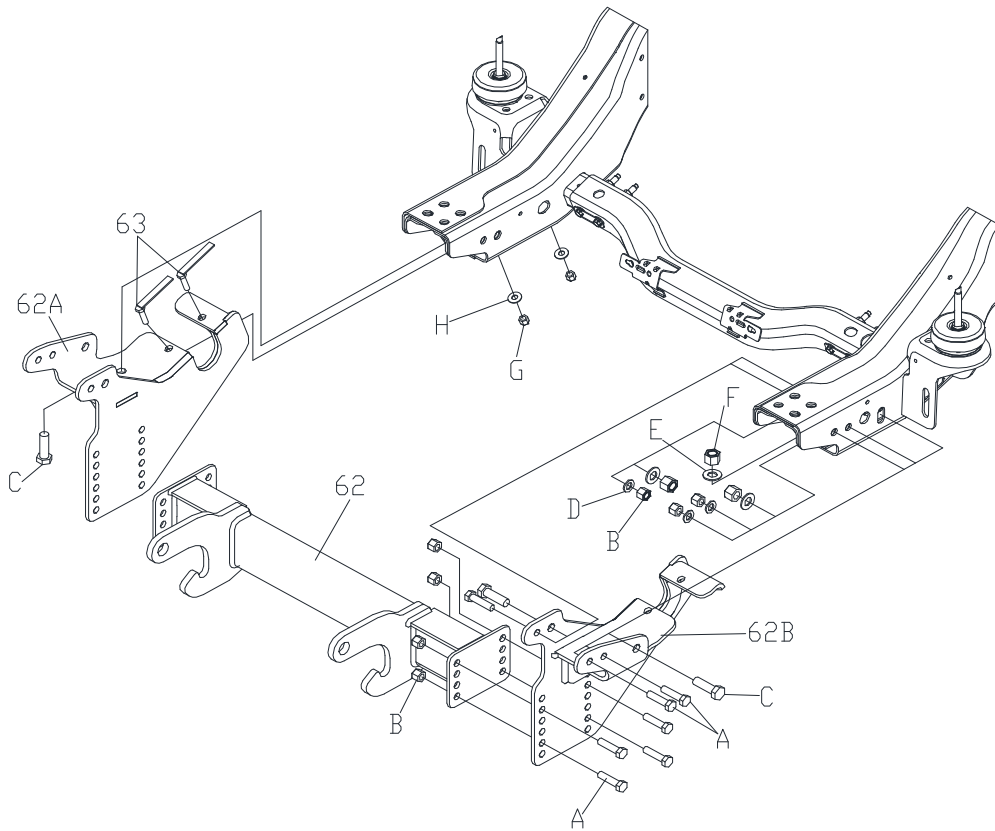

Figure 2

G13964

## RECOMMENDED PUSHBEAM HEIGHT

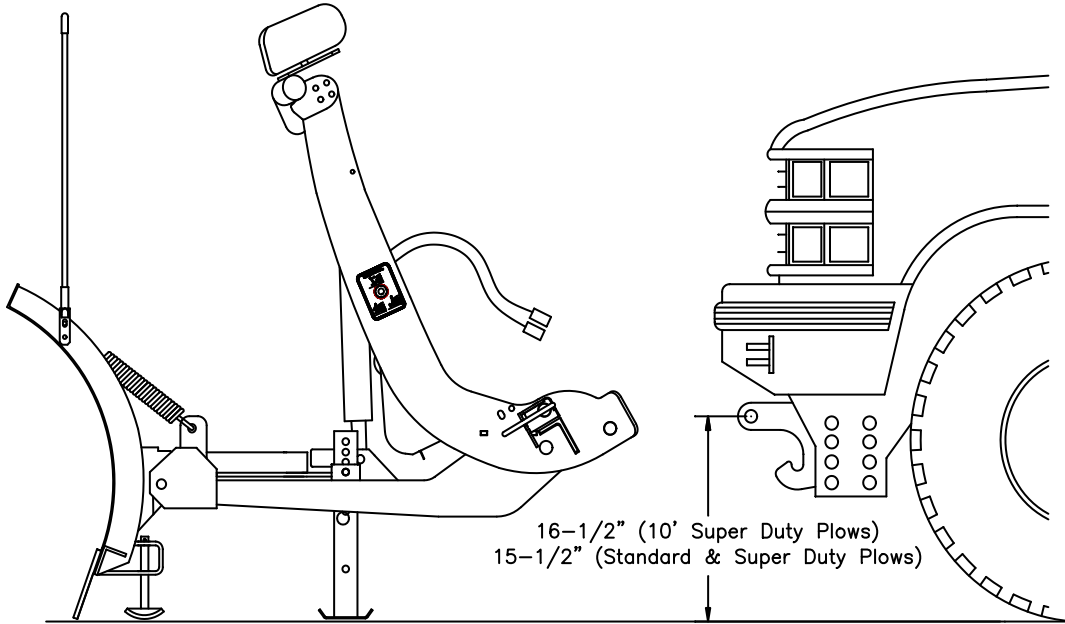
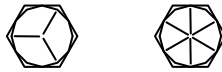

Figure 3

G10155

## GUIDE TO RECOMMENDED ASSEMBLY TORQUE



| DIAMETER / PITCH | GRADE 5 | GRADE 8 | GRADE 8.8 | GRADE 10.9 |
|------------------|---------|---------|-----------|------------|
| 1/4-20           | 6       | 9       |           |            |
| 5/16-18          | 14      | 19      |           |            |
| 3/8-16           | 23      | 33      |           |            |
| 7/16-14          | 38      | 53      |           |            |
| 1/2-13           | 56      | 80      |           |            |
| 9/16-12          | 82      | 116     |           |            |
| 5/8-11           | 113     | 159     |           |            |
| 3/4-10           | 201     | 283     |           |            |
| M10 X 1.25       |         |         | 36        |            |
| M10 X 1.5        |         |         |           | 49         |
| M12 X 1.75       |         |         |           | 71         |
| M14 X 2.0        |         |         |           | 80         |

ALL TORQUE VALUES ARE IN FOOT-POUNDS (FT.-LB.)

Figure 4

G10410

The torque values listed above are based on dry, coated bolts, variables such as oil, or other lubrications may appreciably alter these values and must be taken into consideration.

**NOTE:** IT IS IMPORTANT THAT ALL FASTENERS BE PROPERLY TORQUED TO ASSURE A SAFE OPERATING PLOW. RE-TIGHTEN ALL FASTENERS AFTER 2 HOURS OF PLOWING.